

**Mid-term Examination****Marks: 30**

Open notes but closed books

**Time: 90 minutes****Question 1 (5 marks)**

Consider  $J = \int_{x_1}^{x_2} F(x, y, y', y'', \dots, y^{(n)}) dx$  and  $f(x)$ . What possible terms can you add to the integrand of  $J$  using  $f(x)$  and  $y(x)$  and their derivatives so that the new functional and  $J$  would have the same Euler-Lagrange extremizing differential equation as the extremizing solution?

**Question 2 (5 marks)**

What functional, when optimized, would lead to the Poisson's equation:  $\nabla^2 z(x, y) = g(x, y)$ ? Please also write the boundary condition that arises when such a functional is extremized.

**Question 3 (3+4+1+2 = 10 marks)**

It is desired that an axially loaded fixed-free bar's cross-section area,  $A(x)$ , be designed with a given volume of material,  $V^*$ , such that the overall stiffness and the displacement at a particular point,  $x = \hat{x}$ , are both maximized.

- (a) Justify that the following problem statement meets the above requirements and explain what the symbols in the problem statement stand for.

$$\text{Minimize}_{A(x)} J = \frac{\int_0^L \frac{P^2}{2EA} dx}{\int_0^L \frac{Pq}{EA} dx}$$

Subject to

$$\int_0^L A dx - V^* \leq 0$$

Data:  $E$  = Young's modulus,  $f(x)$  = axial load,  $L$  = length,  $V^*$

- (b) Write down the Euler-Lagrange necessary conditions for this problem (You need not write the boundary conditions).  
 (c) How do you justify that the volume constraint must be active/inactive?  
 (d) Determine the expressions for the optimal  $A(x)$  and the Lagrange multiplier corresponding to the constraint.

**Question 4 (10 marks)**

Write down the extremizing differential equation and the boundary conditions for the following functional if the end points of  $y(x)$  lie on curves  $\phi_1(x)$  and  $\phi_2(x)$ .

$$J = \left\{ \int_{x_1}^{x_2} F(x, y, y') dx \right\} + \psi(x_1, y_1, x_2, y_2)$$

Note that  $y_1 = y_{x=x_1}$  and  $y_2 = y_{x=x_2}$ .

**Mid-term Examination**

**Marks: 30**

Open notes and open books

**Time: 60 minutes**

**Question 1 (10 marks)**

Consider two inner products defined on vector spaces  $X$  and  $Y$  as mappings  $X \times X$  and  $Y \times Y$  respectively into their common scalar field  $K$  and denoted as  $\langle x_1, x_2 \rangle_1$ ,  $x_1, x_2 \in X$  and  $\langle y_1, y_2 \rangle_1$ ,  $y_1, y_2 \in Y$ . Note also that there are the following relationships between  $X$  and  $Y$ .

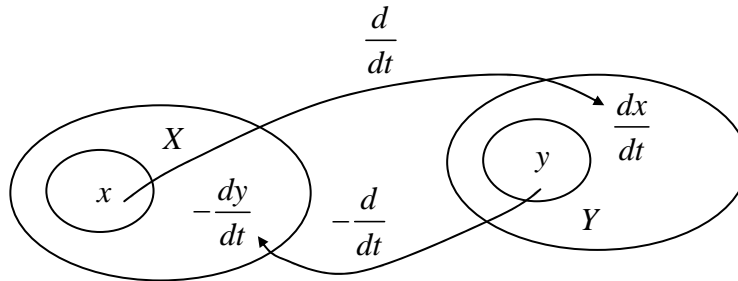

Now, consider  $J = \int_a^b x \frac{dy}{dt} dt$  with  $x(t) \in X$  and  $y(t) \in Y$ .

If the result of the integration by parts of  $J$  can be expressed as  $\langle x, -\frac{dy}{dt} \rangle_1 = \langle y, \frac{dx}{dt} \rangle_2$ , write down the formulae for the two inner products used here.

- Comment on the validity of your definitions of inner products for extra marks of up to 5.

**Question 2 (10 marks)**

Write the Euler-Lagrange equation of the following problem of minimizing a functional of two independent variables.

$$\text{Minimize}_{u(x,y)} J = \iint_R \left[ D \left( \frac{\partial^2 u}{\partial x^2} + \frac{\partial^2 u}{\partial y^2} \right)^2 - 2D(1-\nu) \left\{ \frac{\partial^2 u}{\partial x^2} \frac{\partial^2 u}{\partial y^2} - \left( \frac{\partial^2 u}{\partial x \partial y} \right)^2 \right\} - f(x, y)u \right] dx dy$$

Simplify the Euler-Lagrange equation to the extent possible.

- Extra points will be given for writing the boundary conditions. (Up to 10 extra marks.)

**Question 3** (10 marks)

The figure below shows a horizontal beam of length  $L$ , Young's modulus  $E$ , moment of inertia  $I$ , and loaded with a force  $P$  at its mid point and constrained as follows. The left end is attached to a rigid crank of radius  $r_1$  with a pin joint and a torsional spring of spring constant  $\kappa$ . The right end is fixed to another rigid crank of radius  $r_2$ . The vertical separation between the grounded pivots of the two cranks is shown to be  $e$ . Obtain a functional the minimization of which gives the static equilibrium equation to solve for the deformed configuration of this problem. And then, write the Euler-Lagrange equations along with the boundary conditions in terms of the symbols noted here.

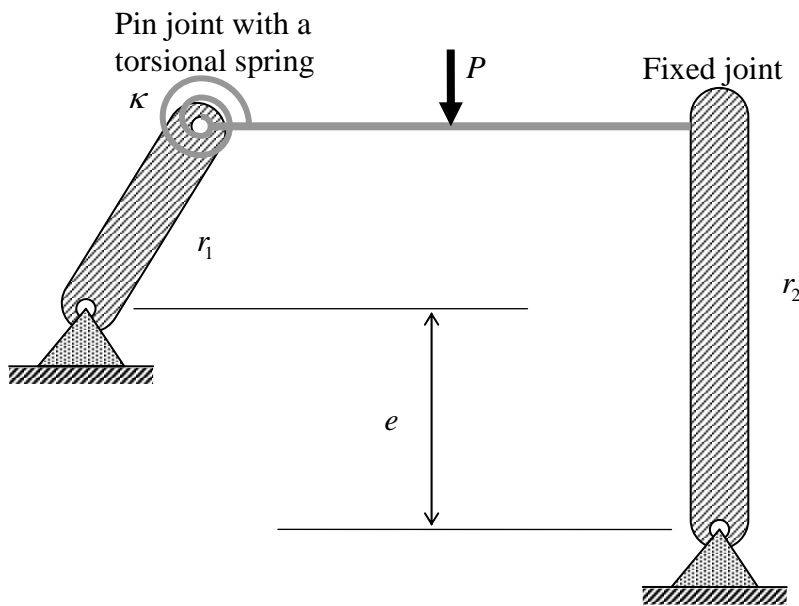

**Mid-term Examination****Marks: 30**

Open notes and open book

**Time: 60 minutes****Question 1 (10 marks)**

The figure below shows a beam of elasticity modulus,  $EI(x)$ , and length,  $L$ , lying on an elastic foundation of linear stiffness,  $k(x)$ . A force,  $P$ , is applied at the mid point as shown. Using the principle of minimum potential energy, derive the governing equation for the elasto-static equilibrium of the beam along with the boundary conditions.

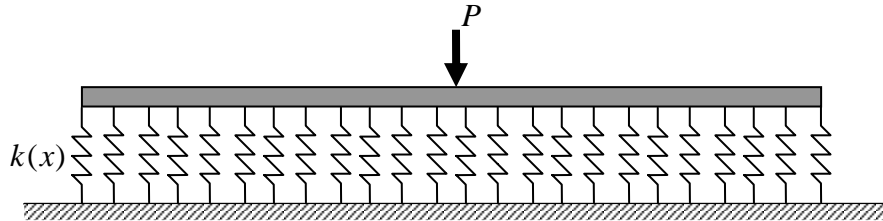
**Question 2 (10 marks)**

For a system of  $N$  particles, the time-dependent functions of the generalized coordinates  $q_i(t)$  where  $(i=1 \dots N)$  can be found by using the Hamilton's principle. This principle states that

the Hamiltonian,  $H$ , defined as  $H = KE - PE = \left\{ \sum_{i=1}^N 0.5m_i \left( \frac{dq_i}{dt} \right)^2 \right\} - PE(q_1, q_2, \dots, q_N)$  is stationary

with respect to  $q_i (i=1 \dots N)$ . Note that  $KE$  is the kinetic energy and  $PE$  is the potential energy. First, write down the Euler-Lagrange necessary conditions for the stationarity of the Hamiltonian. Next, show that conservation of the energy follows from this principle. That is, show that  $(KE + PE)$  is equal to a constant for  $q_i(t)$ s that satisfy the stationarity equations of  $q_i (i=1 \dots N)$ .

**Question 3 (10 marks)**

Two inhomogeneous transparent slabs are connected as shown in the figure below. The refractive indices,  $n_1(x)$  and  $n_2(x)$ , of the two slabs vary as indicated in the figure. Note that  $n_1 \neq n_2$  at the interface,  $x = L_1$ . First, Write down the calculus of variations problem to minimize the transit time for a light ray to travel from  $A$  to  $B$  following a path,  $y(x)$ . Next, obtain the differential equation helps in solving for  $y(x)$ . Comment on the nature of the solution, write down the boundary conditions and sketch the solution of the path taken by the light ray.

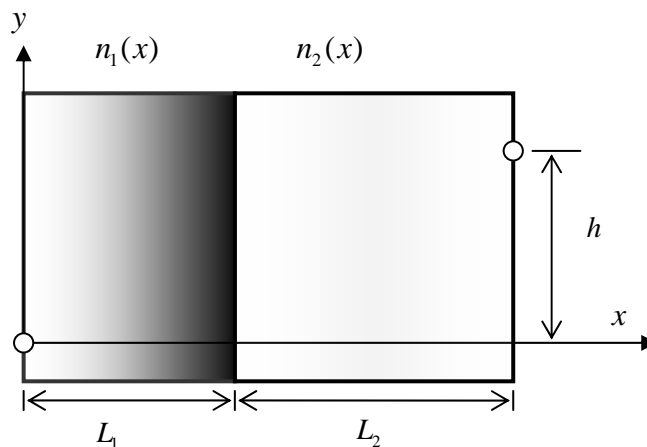

**Mid-term Examination****Marks: 30**

Open notes and open book

**Time: 90 minutes****Question 1 (14 marks)**

A chain that has a uniform mass per unit length of  $\gamma$  and length  $L$  is tied to two points on a disk as shown in the figures below. In Fig. A, both ends are fixed to the disk as shown. In Fig. B, one end is fixed while the other end is movable in a circumferential slot. The disk is oriented horizontally and is rotating about the vertical axis at a constant angular velocity,  $\omega$ . Note that a centripetal force of  $m r \omega^2$  acts on a mass  $m$  located at a distance  $r$  away from the centre and rotating at an angular velocity  $\omega$ .

- First, for the chain attachment as shown in Fig. A, formulate a calculus of variations problem to find the shape of the chain as the disk rotates. Obtain the governing differential equation (no need to simplify) and the boundary conditions.
- What in your formulation changes when one end is constrained to move in a circumferential slot as shown in Fig. B?
- (For 5 extra marks) Comment on the nature of the solutions. Using your intuition and/or careful study of your governing equations, sketch approximate optimum chain shapes in both cases.

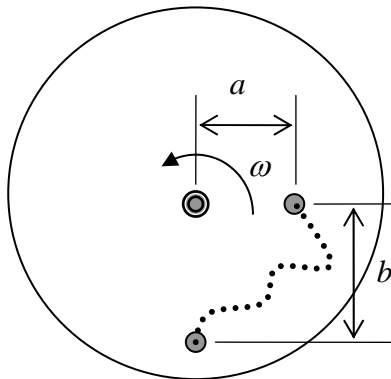

Fig. A

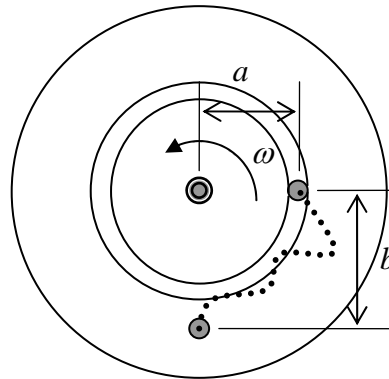

Fig. B

**Question 2 (8 marks)**

Obtain a *nontrivial* functional, which when extremized, gives the following differential equation as a necessary condition.

$$y''(x) + c_1 y'(x) + c_2 y(x) = c_3$$

where  $c_{i=1,2,3}$  are constants. Write the Euler-Lagrange equations for your functional and verify that you get the above differential equation as part of the necessary conditions. Do not worry about the boundary conditions.

**Question 3 (8 marks)**

A functional,  $\int_0^1 \{(y')^3 + 2yy''\} dx$ , is to be minimized with respect to an unknown function,  $y(x)$ . A

solution has not been found yet. Someone started with a function,  $y(x) = x^3 - x$  that does not minimize the functional, but wants to know the following: at which value of  $x = \hat{x}$  the functional is most sensitive for a small change to  $y(x)$  at  $x = \hat{x}$ ? Please determine  $\hat{x}$  accordingly. Show all your work with details.

**Mid-term Examination****Marks: 30**

Open notes and open books

**Time: 90 minutes****Question 1 (10 marks)**

The figure below shows a segmented beam of length  $l$  with uniform beam modulus  $EI$  along its length. There is a pin joint at one third the length from the left and a downward point load  $F$  at one third the length from the right. The left end is fixed and the right end pinned as shown. Use the principle of minimum potential energy to write down the differential equation, the end conditions, and the conditions at the intermediate pin joint. Sketch the deformed shape qualitatively.

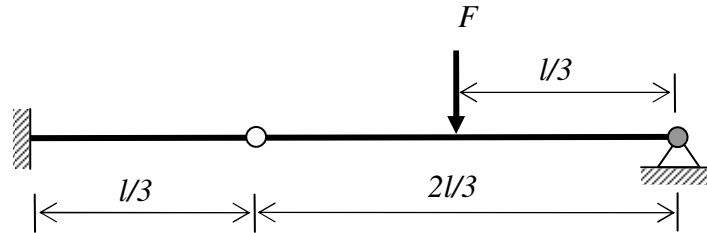
**Question 2 (10 marks)**

Consider the functional  $\int_{-2}^2 y^2 \sqrt{1+y'^2} dx$ . We want to find the minimizing function  $y^*(x)$  for the functional by starting with a given function,  $y(x) = x+1$ , and modifying it gradually. Assume that  $y(x) = x+1$  satisfies the prescribed  $y$  values at both the ends. The modification procedure involves a slight change (positive or negative) in  $y(x)$ , say 0.01, at each point  $x$  such that the value of the functional decreases. Now answer the following.

- (i) In the first step, how would you determine at which values of  $x$  you would increase  $y(x)$  and at which values of  $x$  you would decrease  $y(x)$ .
- (ii) Do you think such a procedure would converge to the minimizer of the functional? If yes, explain why. If not, what change would you suggest for making it converge?

**Question 3 (10 marks)**

We want to optimize  $J = \frac{\int_0^a by'^2 dx}{\int_0^a y^2 dx}$  with respect to  $y(x)$  such that  $y(0) = y(a) = 0$ .

- (i) Derive the differential equation using which we can solve this problem.
- (ii) Comment on the nature and the number of solutions for the differential equation.

Show your steps clearly.

**Mid-term Examination****Marks: 30**

Open notes and open books

**Time: 60 minutes**

Show your steps clearly so that your thought process is easily discernible.

**Question 1 (6 marks)**

The figure below shows a hinged rod holding a mass  $m$  under gravity and restrained by a linear spring of constant  $k$ . Assume that the rod is rigid and that its mass as well as that of the spring can be neglected. The spring is special in that its length in its unloaded state is zero. That is, its free length is zero. Therefore, the force exerted by it is  $k$  times its length at any instant. Your task is to find a relationship among the quantities shown so that this system is in static equilibrium for any configuration as the rod rotates about its hinge point A.

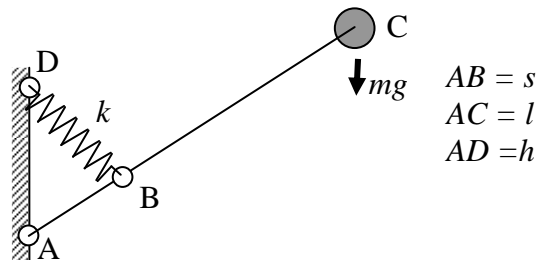
**Question 2 (10 marks)**

A projectile is a body thrown up against gravity. Imagine a projectile as a particle thrown with some initial velocity from a point and coming down to another point that lies on a horizontal line passing through the starting point. You are asked to find the trajectory of this projectile such that its length is optimized while obeying projectile's law of motion. See the figure for clarity.

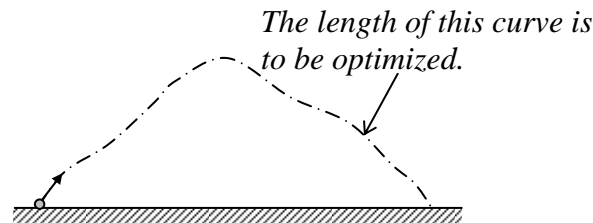

- (i) Pose this as a problem of calculations of variations. Write the mathematical statement of the problem in the standard form. Write the necessary conditions including the boundary conditions.
- (ii) Solve the problem and give the complete specification of the trajectory.

**Question 3 (14 marks)**

We want to minimize  $J = \frac{\int_{x_1}^{x_2} F_1(y, y', x) dx}{\int_{x_1}^{x_2} F_2(y, y', x) dx}$  with respect to  $y(x)$ .

- (i) Derive the differential equation using which we can solve this problem.
- (ii) Write the boundary conditions for this problem when the limits  $x_1$  and  $x_2$  are fixed.
- (iii) How do the boundary conditions change when the limit  $x_2$  is variable?
- (iv) What changes happen to the differential equation and the boundary conditions (cases ii and iii) when the numerator of the objective function is changed to  $F_1(y, y', y'', x)$ ?

**Mid-term Examination****Marks: 30**

Open notes and open books

**Time: 60 minutes**

Show your steps clearly so that your thought process is easily discernible.

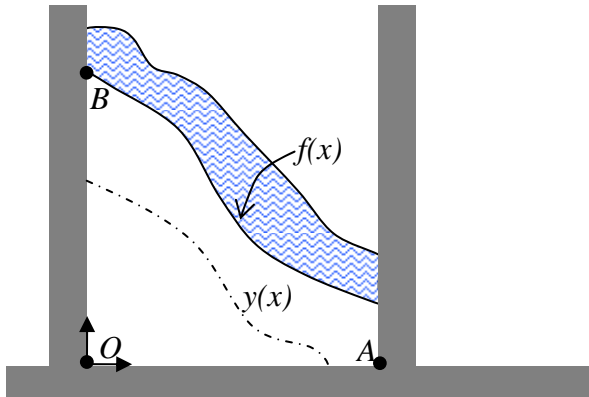
**Question 1 (12 marks)**

Given three roads and a river as shown in the picture, we want to enclose a specified area  $S^*$  below the river and bounded by the roads such that the boundary of the field, not counting the length of the roads, is minimized. Let  $O$  be the origin of the coordinate system with horizontal and vertical axes in which  $f(x)$  is the equation of the lower bank of the river and  $A$  and  $B$  have coordinates:  $(l, 0)$  and  $(0, v)$ . If  $y(x)$  denotes the boundary of the field,

find the differential equation and all the conditions that will enable us to solve for  $y(x)$  completely for all values of the data of this problem. Comment on the nature of the solution in various cases.

**Question 2 (8 marks)**

Given a functional  $J = \int_a^b \{A(x)^2 y'^2 + B(x)y^2\} dx$ ,

- show that its extremum value with respect to  $y(x)$  does not depend on  $B(x)$  by writing its Euler-Lagrange equation.
- Show also that  $\text{extremum}(J) = \left(A(x)^2 y y'\right)\Big|_a^b$  without having to solve the Euler-Lagrange equation.

**Question 3 (10 marks)**

By writing the necessary conditions of the following calculus of variations problem,

$$\text{Min}_{u(x)} \text{Max}_{A(x)} PE = \int_0^L \left\{ \frac{EAu'^2}{2} - pu \right\} dx$$

Subject to

$$\int_0^L A dx - V^* \leq 0$$

Data:  $L, E, p(x), V^*$

verify that it is equivalent to the minimization of  $\int_0^L pu dx$  with respect to  $A(x)$  subject to the

governing equation (i.e.,  $(EAu')' + p = 0$ ) on  $u(x)$  and the volume constraint. Explain also why  $PE$  ought to be maximized with respect to  $A(x)$ .